

Product Brief

## AMC Development Carrier

### Key Benefits

Catch the ATCA Wave

Fast track your product development

The ATCA compliant Advanced Mezzanine Card (AMC) Development Carrier, by Accipiter Systems, is an ATCA standard carrier with provisions for the latest in high-speed communications. With carrier based switchable redundant 10 Gbps XAUI busses and dual 10/100/1000Base-T routing to the AMC slots, this carrier enables the next generation of communication AMCs.

#### Smart

With an on-board Intelligent Platform Management Controller (IPMC), carrier health is monitored and relayed to the ATCA shelf manager. Hot swapping is also

controlled. Lastly, the XAUI crossbar switch ICs can be controlled to route 10 Gbps data between AMCs on the carrier and the ATCA backplane.

#### Speeds Custom AMC Development

With the ATCA AMC Development Carrier complete, tested, and complying with all of the appropriate standards and certifications, engineers and designers can focus on their value add functions on the AMC, and dramatically reduce the time to market.

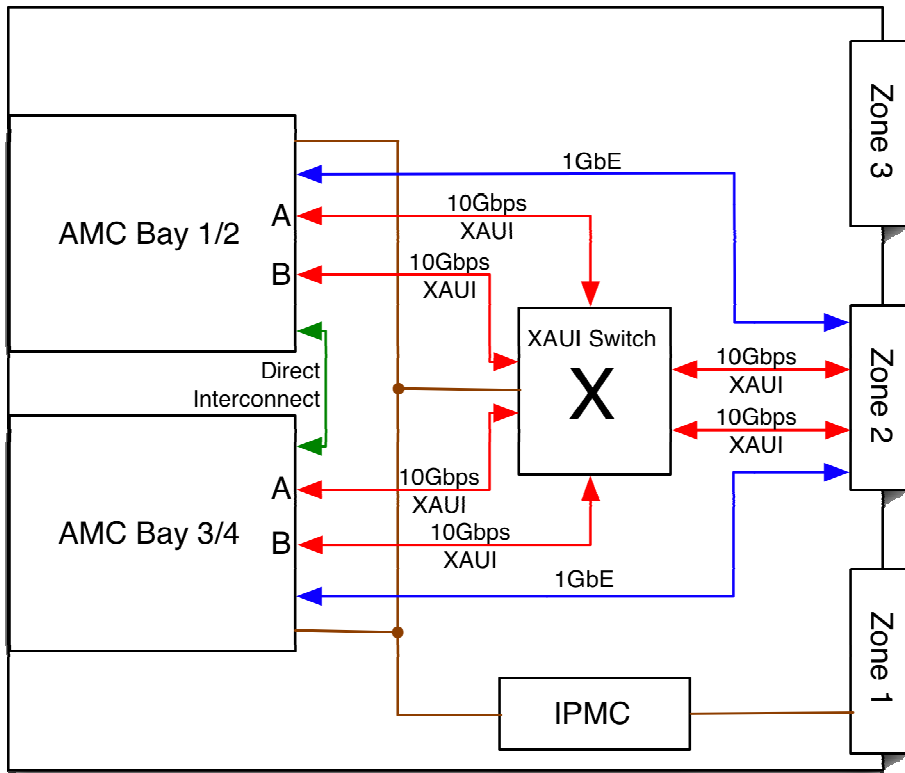

Specifications

Bus types

PICMG 3.0, PICMG 3.1 option 9 compliant carrier board containing:

- Backplane: Redundant bidirectional XAUI switchable on carrier, Dual 10/100/1000Base-T
- Two AMC slots: Bidirectional 10Gbps XAUI, 10/100/1000Base-T, I<sup>2</sup>C, Proprietary Control and MDIO bus

Full Hot-Swap capabilities

<b>Clocking/Synchronization</b>	Telco Clock for all AMC slots
<b>Hardware certifications</b>	FCC B, UL, CE, VCCI, BSMI, CTICK, MIC
<b>Typical power consumption</b>	15 watts
<b>Airflow</b>	50 CFM (Cubic Feet per Minute)
<b>Operating temperature</b>	0°C-50°C
<b>Storage temperature</b>	-40°C to 70°C
<b>Physical Dimensions</b>	35.1 cm x 3.048 cm x 30.5 cm
<b>Standards Compliance</b>	PICMG 3.0/3.1 option 9 - AMC.0 rev 2, AMC.2 and AMC.3 PICMG Advanced Mezzanine Card Base Specification - AMC.1 – AMC.4 - IPMI v1.5

<b>Management</b>	SNMP, TELNET, CLI, either In-band or Out of band via 10/100Base-T Ethernet or RS232 IPMI version 1.5 support
-------------------	---

<b>IPMI</b>	<ul style="list-style-type: none"> <li>• Dedicated µController</li> <li>• PICMG 3.0 / IPMI 1.5 compliant</li> <li>• Dedicated µController as additional Firmware Update Manager</li> <li>• (FWUM) for field upgrades, rollbacks and watchdog functions</li> </ul>
-------------	---

Common XAUI Switch Configurations

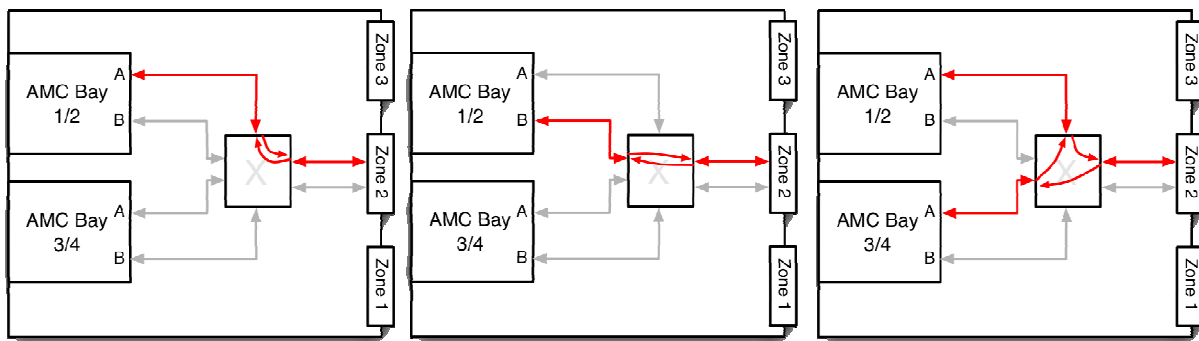

Ordering Information

Accipiter Systems SKU

ASI-ATCA-AMCDC

Product Description

Advanced Mezzanine Card Development Carrier



**Accipiter Systems**  
412 Fox Meadow Drive  
Wexford, PA 15090  
Main Phone: 412.253.0623  
Fax: 724.933.8838

[www.AccipiterSystems.com](http://www.AccipiterSystems.com)

Information:  
[info@accipitersystems.com](mailto:info@accipitersystems.com)